

CB 1/6-2/4 PT-BE

Push-in base element, 1-position, to accommodate 1 or 2-position thermomagnetic and 1-position electronic device circuit breakers

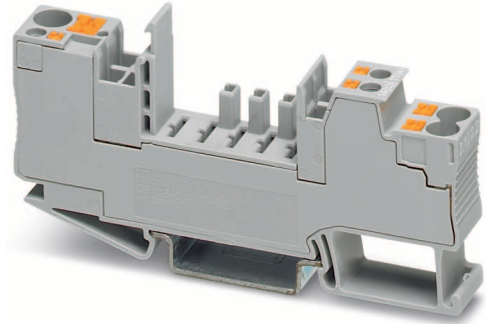

Data Sheet
105219_en_00

© PHOENIX CONTACT 2012-05-09

1 Description

The CB 1/6-2/4 PT-BE base element can accommodate thermomagnetic and electronic device circuit breakers of the CB TM... (thermomagnetic) and CB E... (electronic) type.



Make sure you always use the latest documentation.
It can be downloaded at www.phoenixcontact.net/catalog.



This data sheet is valid for all products listed on the following page:



2 Ordering data

Base element

Description	Type	Order No.	Pcs. / Pkt.
Base element , 1-position, to accommodate 1 or 2-position thermomagnetic and 1-position electronic device circuit breakers such as CB TM... or CB E..., grey	CB 1/6-2/4 PT-BE	2800929	10

Accessories

Description	Type	Order No.	Pcs. / Pkt.
Plug-in bridge, for cross connection in the bridge shaft, red, 2-pos.	FBS 2-6*	3030336	50
Plug-in bridge, for cross connection in the bridge shaft, red, 3-pos.	FBS 3-6*	3030242	50
Plug-in bridge, for cross connection in the bridge shaft, red, 4-pos.	FBS 4-6*	3030255	50
Plug-in bridge, for cross connection in the bridge shaft, red, 5-pos.	FBS 5-6*	3030349	50
Plug-in bridge, for cross connection in the bridge shaft, red, 10-pos.	FBS 10-6*	3030271	10
Plug-in bridge, for cross connection in the bridge shaft, red, 20-pos.	FBS 20-6*	3030365	10
Plug-in bridge, for cross connection in the bridge shaft, red, 50-pos.	FBS 50-6*	3032224	10
UniCard sheet, for labeling	UC-TMF	(See catalog)	
Zack marker strip, for labeling	ZBF	(See catalog)	
Coding star (red)	PC	3040588	50

* Bridge current of 32 A, maximum

3 Technical data

Environmental tests (typical values)

Vibrations (tested according to DIN EN 50155/VDE 0115-200)	Category 1, Class B
Shock (tested according to DIN EN 50155/VDE 0115-200)	5g/30 ms
Corrosion (tested according to DIN 50018-KFW)	1.0 I
Degree of protection (IEC 60529, DIN VDE 0470)	
Operating range	IP30
Range of connection for the base element CB 1/6-2/4 PT-BE	IP20
Test mark in preparation	UL
Nominal voltage	300 V
Rated insulation voltage	250 V
Rated current (maximum)	16 A
Ambient temperature range	-40°C ... +120°C

General data

Mounting method	Installation on DIN rail NS 35 acc. to EN 60715
Plug-in bridge, for cross connection in the bridge shaft	FBS... (See „Accessories“ auf Seite 2)
Weight (base element)	29.5 g
Housing material	PA 6.6
Inflammability class according to UL 94	V0
Insulation material group	I
Pollution degree	3
Surge voltage category	III
Rated surge voltage	4 kV
Insertion/withdrawal cycles	100 x

Connection		
Connection capacity of connection 1		
Solid	0.5 mm ² ... 6 mm ² (AWG 20 ... 10)	1 mm ² ... 6 mm ²
Stranded	0.5 mm ² ... 6 mm ²	–
Stranded, with ferrule (with plastic sleeve)	0.5 mm ² ... 6 mm ²	0.5 mm ² ... 6 mm ²
Stranded with ferrule (without plastic sleeve)	0.5 mm ² ... 6 mm ² (10 mm ²)*	0.5 mm ² ... 6 mm ² (10 mm ²)*
Stranded, with TWIN ferrule	0.5 mm ² ... 1 mm ²	–
Connection capacity of connections 2.1/2.2		
Solid	0.2 mm ² ... 6 mm ² (AWG 24 ... 10)	0.5 mm ² ... 6 mm ²
Stranded	0.2 mm ² ... 4 mm ²	–
Stranded, with ferrule (with plastic sleeve)	0.25 mm ² ... 4 mm ²	0.75 mm ² ... 4 mm ²
Stranded with ferrule (without plastic sleeve)	0.25 mm ² ... 4 mm ²	0.5 mm ² ... 4 mm ²
Stranded, with TWIN ferrule	0.5 mm ² ... 1 mm ²	–
Connection capacity of connections 12/11/14 (PDT)		
Solid	0.14 mm ² ... 1.5 mm ² (AWG 26 ... 14)	0.25 mm ² ... 1.5 mm ²
Stranded	0.14 mm ² ... 1.5 mm ²	–
Stranded, with ferrule (with plastic sleeve)	0.14 mm ² ... 1.5 mm ²	0.34 mm ² ... 1.5 mm ²
Stranded with ferrule (without plastic sleeve)	0.14 mm ² ... 1 mm ²	0.34 mm ² ... 1 mm ²
Stranded, with TWIN ferrule	–	–
Stripping length		
Connections 1 and 2.1/2.2	12 mm	
Connections 12/11/14	8 mm	

* 10 mm²: stranded with ferrules without insulating collar, when crimped with the CRIMPFOX UD 10-4 or CRIMPFOX 10S pliers

4 Dimensions

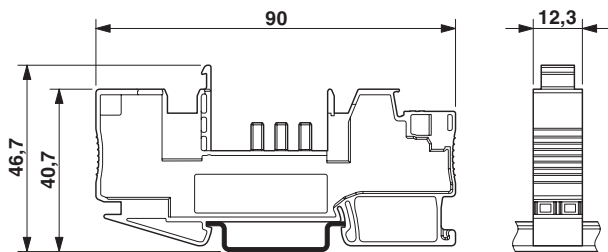

Figure 1 Dimensions (in mm)

5 Connecting the conductor

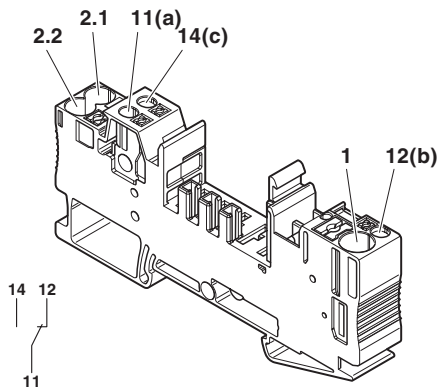

Figure 2 Connections

1	Power supply
2.1/2.2	Power distribution
11 (a)	PDT contact
14 (c)	
12 (b)	

Push-in connection technology

- With the push-in connection technology you insert the insulated conductor (cross section $\geq 0.25 \text{ mm}^2$, solid or with ferrule) into the round opening of the terminal block with a tool.
- You must push in the orange pushbutton to order to open the spring for conductors with a smaller cross section or stranded conductors without ferrule.
- For release, push in the orange pushbutton with a screw driver.

6 Keying the base element

We recommend to key the base element with the associated circuit breaker.

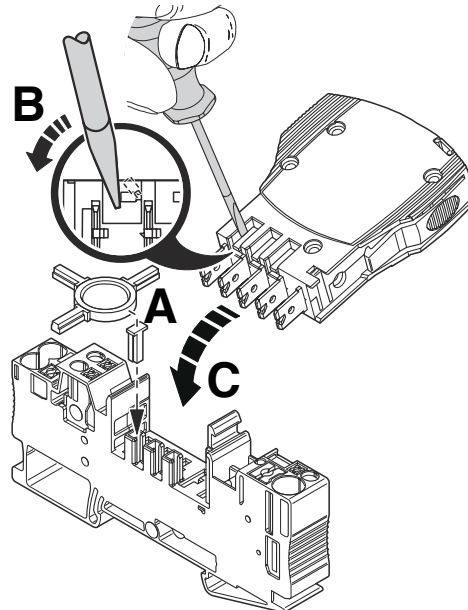

Figure 3 Keying

- A** Remove one element from the coding star to mark one of three possible places on the base element.
- B** Break out the corresponding tab on the circuit breaker.
- C** Insert the circuit breaker into the base element.

7 Inserting plug-in bridges

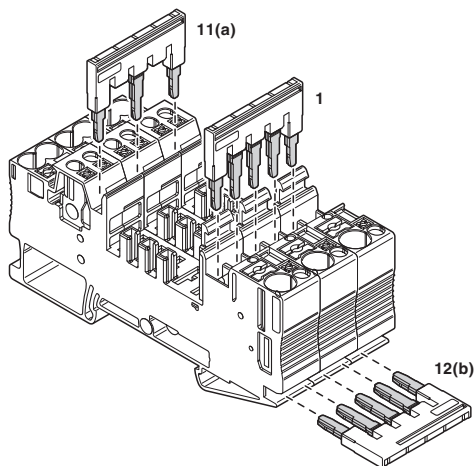

Figure 4 Bridge contacts 1, 11, and 12

The base element has separate bridging shafts for potential distribution.

You can prepare the plug-in bridges (FBS...) by removing the contact tabs or cutting the bridges to the desired length.



WARNING: Once you have removed contact tabs or cut the plug-in bridges to the desired length, you must use the plug-in bridges in touch-protected, closed applications only.



NOTE: The maximum current load is 41 A when two plug-in bridges are used.